

TSUBAKI

PIN GEAR DRIVE UNITS

Standard Series/S Series

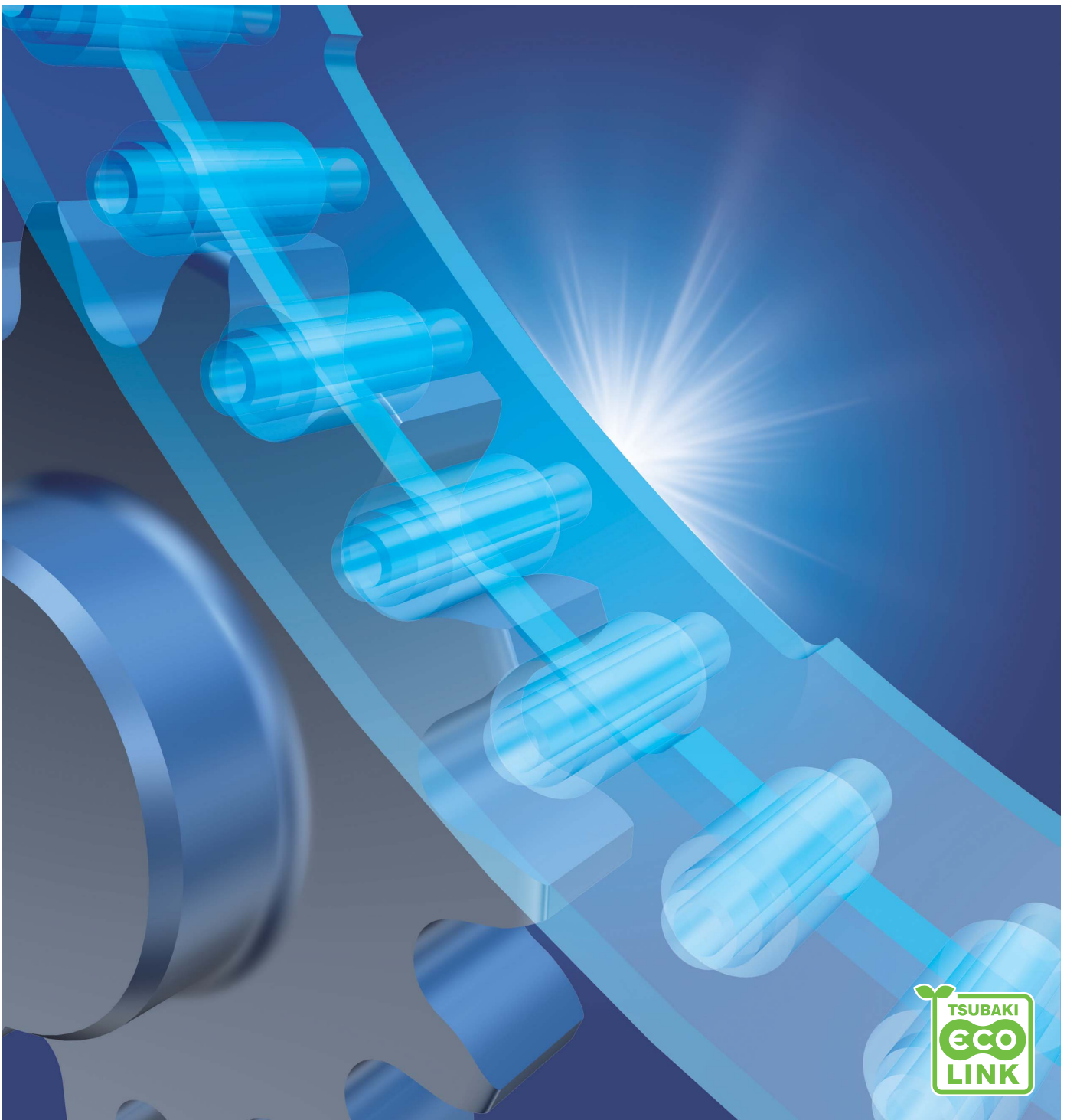

The Tsubaki pin gear drive unit is a new drive unit that replaces gear rack systems.

The combination of a pin-structure wheel/rack and a gear with special tooth profile allows greater freedom when designing rotating or linear drive units.

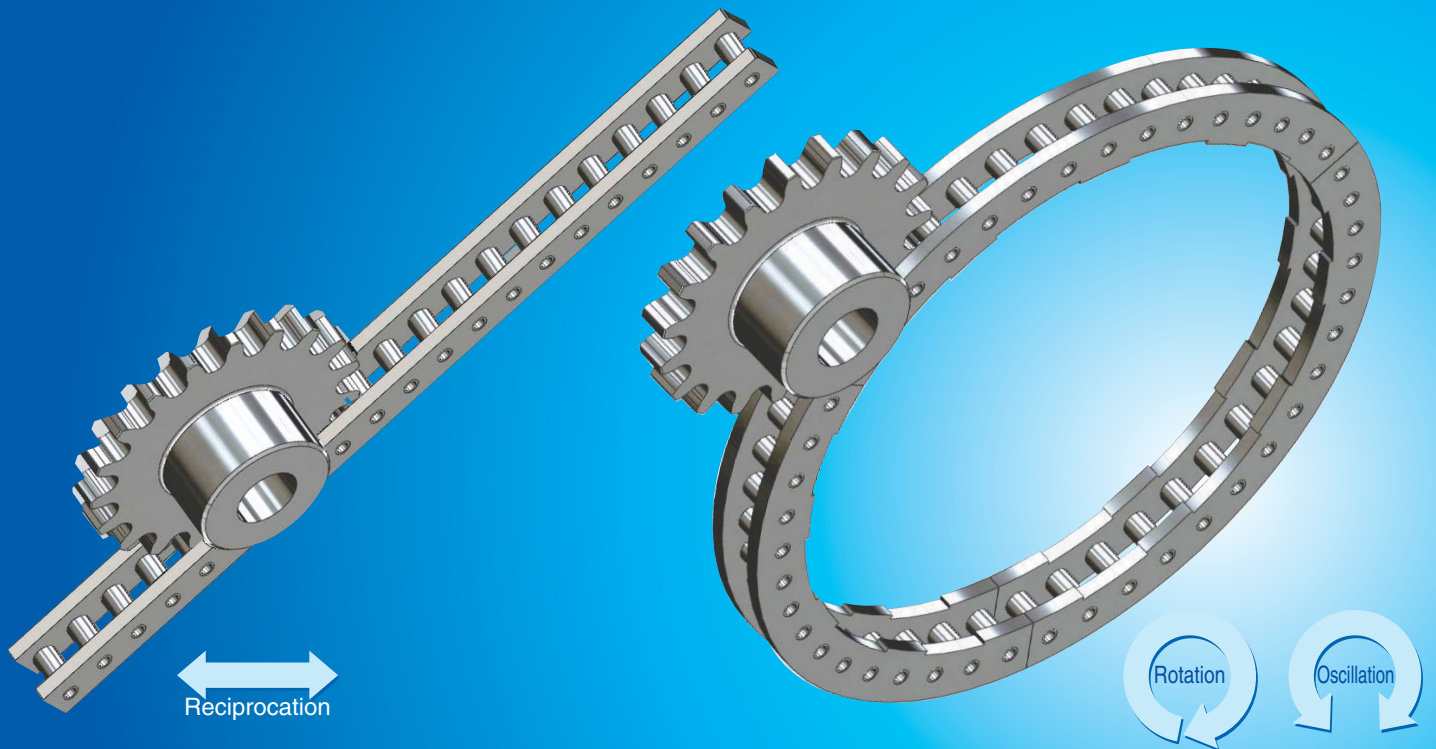

Features

- **Easy installation**
 Employs a separable segment design to ensure easy installation.
 Can be used even with rough installation precision.
- **Large transmission torque**
 Pin gear is designed in forging modules and good pin wheel/rack balance delivers large transmission torque.
- **Can be used in large-scale equipment.**
 Wheel type units can be employed in large drive units by increasing the number of segments.
- **Wide applications**
 Available in steel, stainless steel, and surface-coated models.

Drive system	Installation man-hours	Transmission torque	Large equipment	Cost
Pin gear drive	○	○	○	○
Ordinary gear	△	○	△	×
Chain-type pin gear	△	○	○	◎

Configurations

A pin gear drive unit is a set consisting of pin gear and pin wheel (or pin rack).

Rotational drive

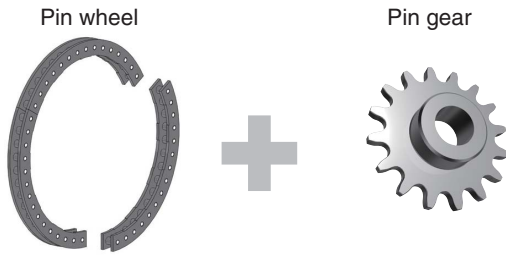

Pin wheel diameter (number of pins) can be chosen freely.

Linear drive

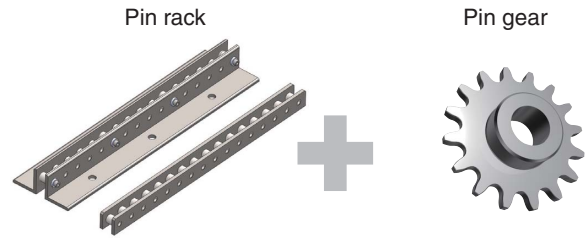

Pin rack length (number of pins) can be chosen freely.

Structure

Pin gear feature specially designed teeth that engage continually and smoothly with the rollers. Teeth are hardened to improve strength and wear resistance.

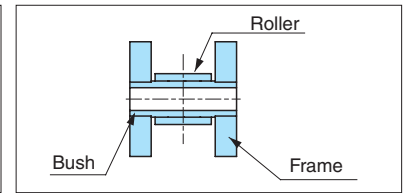
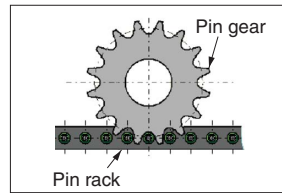

Unique Tooth Profile

The tooth profile is based on an approximate involute to ensure that it can engage smoothly with the pin wheel/rack, and employs a unique design to further increase strength.

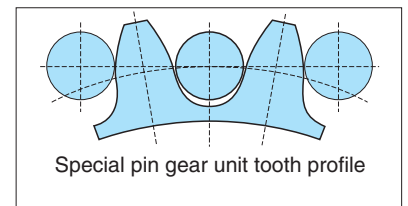

Standard Specifications

Pitch mm	Standard Series (Steel)		S Series (Stainless)	
	Frame No.	Allowable Tangential Load Fp (kN)	Frame No.	Allowable Tangential Load Fp (kN)
20	PDU20	4.7	PDUS20	0.8
22	PDU22	7.7	PDUS22	1.1
30	PDU30	12.8	PDUS30	1.9
35	PDU35	19.5	PDUS35	2.6
40	PDU40	27.3	PDUS40	4.1
50	PDU50	31.7	PDUS50	5.1
55	PDU55	52.9	PDUS55	7.0
70	PDU70	60.7	PDUS70	9.9
80	PDU80	71.5	PDUS80	12.0
90	PDU90	98.9	PDUS90	16.8
120	PDU120	122.5	—	—
Maximum Speed	Tangential speed: 50m/min.			
Usage Environment	Indoors (somewhere unaffected by rain or water)		Corrosive atmospheres	
Usage Temperature	-10°C to 150°C		-20°C to 400°C	
Materials	Frame	Rolled steel	Frame	Austenitic stainless steel
	Bush, Roller	Alloy steel	Bush, Roller	Precipitation hardened stainless steel, others
	Pin gear	Carbon steel	Pin gear	Austenitic stainless steel

*Pin wheel pitch notation indicates circular arc pitch.

Backlash (Reference)

Frame No.	Standard Series (Steel) (mm)	S Series (Stainless) (mm)
PDU(S)20	0.26 to 0.47	0.26 to 0.47
PDU(S)22	0.32 to 0.57	0.32 to 0.57
PDU(S)30	0.32 to 0.66	0.32 to 0.67
PDU(S)35	0.33 to 0.88	0.33 to 0.88
PDU(S)40	0.41 to 0.86	0.41 to 0.86
PDU(S)50	0.53 to 0.98	0.53 to 1.08
PDU(S)55	0.61 to 1.06	0.61 to 1.26
PDU(S)70	0.86 to 1.24	0.86 to 1.61
PDU(S)80	0.89 to 1.20	0.89 to 1.74
PDU(S)90	0.97 to 1.42	0.97 to 1.92
PDU120	1.30 to 1.57	—

*The above backlash amounts are calculated figures and are not guaranteed values. Contact Tsubaki if smaller backlash is desired.

Pin Wheel Products and Specifications

Standard Series (Steel) and S Series (Stainless)

Outer drive pin wheel
(4-segment model shown)

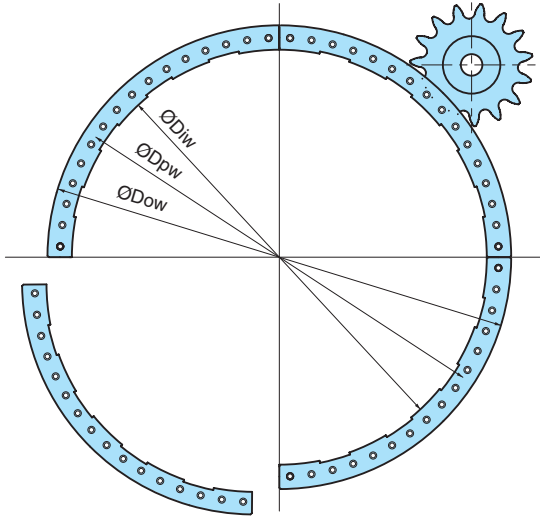

Inner drive pin wheel
(4-segment model shown)

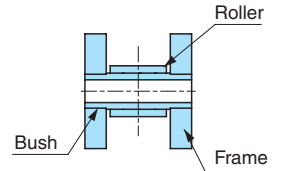
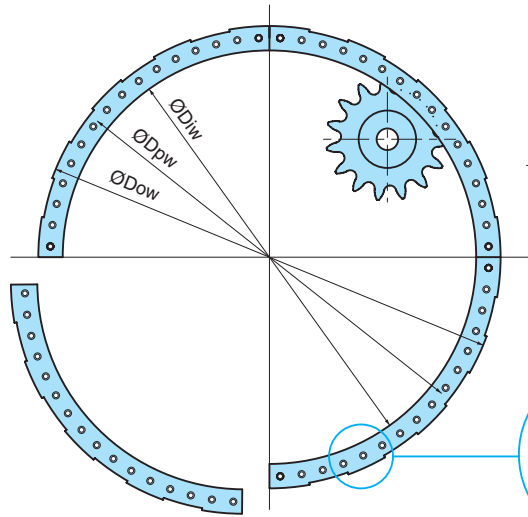

- Notes:
1. There are projections on the inner rim of outer drive pin wheel segments and on the outer rim of inner drive pin wheel segments. These projections serve as the reference surface when installing the pin wheel on the device with which it is to be used.
 2. The inner diameter (Diw) of outer drive wheels and the outer diameter (Dow) of inner drive wheels are respectively the outer/inner diameter of the device with which the pin wheel is to be used.
 3. See page 8 for installation instructions.
 4. Mounting bolts are not included.
 5. We can produce pin wheels with roller quantities other than those noted in this catalog.
 6. We can also make pin wheels for partial circumferences (i.e. less than 360°).

Example Model No.

P D U 7 0 - G W - 7 0 P

Frame No.	Pin Wheel	Roller Qty
PDU : Standard series	GW : Outer drive	
PDUS : S series	NW : Inner drive	

Reference:

Example model No. for pin wheel with partial circumference (i.e. less than 360°).

P D U 7 0 - G W - 3 0 / 9 0 P

Required Roller Qty	Roller Qty for Full Circumference

Notification of Changes to Specifications (From April 2012)

- All frame pins are with hollow type (bush).
- S series (stainless) models are now the same structure as the standard series. (Consult us if you require models with old specifications due to replacement or other reasons.)

Frame No.	PDU20 (Standard Series) PDUS20 (S Series)				PDU22 (Standard Series) PDUS22 (S Series)				PDU30 (Standard Series) PDUS30 (S Series)			
	Circular Arc Pitch P		20		Circular Arc Pitch P		22		Circular Arc Pitch P		30	
Specs	Roller Diameter ød		10.16		Roller Diameter ød		11.91		Roller Diameter ød		15.88	
	Overall Width Lw		Standard: 21 S: 22		Overall Width Lw		Standard: 25 S: 26		Overall Width Lw		Standard: 31 S: 31	
	Inside Width W		12		Inside Width W		16		Inside Width W		19	
	Plate Thickness T		Standard: 4.5 S: 5		Plate Thickness T		Standard: 4.5 S: 5		Plate Thickness T		Standard: 6 S: 6	
	Mounting Hole ødm		4.5		Mounting Hole ødm		4.5		Mounting Hole ødm		6.4	
	Mounting Bolt Size		M4		Mounting Bolt Size		M4		Mounting Bolt Size		M6	
	Roller Qty NT	Segment Qty	Pitch Diameter Dpw	Outer Diameter Dow	Inner Diameter Diw	Segment Qty	Pitch Diameter Dpw	Outer Diameter Dow	Inner Diameter Diw	Segment Qty	Pitch Diameter Dpw	Outer Diameter Dow
60	1	381.97	404	359	1	420.17	445	396	1	572.96	605	540
70	1	445.63	468	423	1	490.20	515	466	1	668.45	701	636
80	1	509.30	532	487	1	560.23	585	536	1	763.94	796	731
90	1	572.96	595	550	1	630.25	655	606	3	859.44	892	827
100	1	636.62	659	614	1	700.28	725	676	4	954.93	987	922
110	1	700.28	723	678	1	770.31	795	746	4	1050.42	1083	1018
120	1	763.94	786	741	3	840.34	865	816	5	1145.92	1178	1113
130	3	827.61	850	805	4	910.37	935	886	5	1241.41	1274	1209
140	3	891.27	914	869	4	980.39	1005	956	6	1336.90	1369	1304
150	4	954.93	977	932	4	1050.42	1075	1026	6	1432.39	1465	1400
160	4	1018.59	1041	996	5	1120.45	1145	1096	6	1527.89	1560	1495
170	4	1082.25	1105	1060	5	1190.48	1215	1166	7	1623.38	1656	1591
180	5	1145.92	1168	1123	5	1260.51	1285	1236	7	1718.87	1751	1686
190	5	1209.58	1232	1187	5	1330.54	1355	1306	8	1814.37	1847	1782
200	5	1273.24	1296	1251	6	1400.56	1425	1376	8	1909.86	1942	1877
220	6	1400.56	1423	1378	6	1540.62	1565	1516	9	2100.85	2133	2068
240	6	1527.89	1550	1505	7	1680.68	1705	1656	9	2291.83	2324	2259
260	7	1655.21	1678	1633	8	1820.73	1845	1796	10	2482.82	2515	2450
280	7	1782.54	1805	1760	8	1960.79	1985	1936	11	2673.80	2706	2641
300	8	1909.86	1932	1887	9	2100.85	2125	2076	12	2864.79	2897	2832

Frame No.	PDU35 (Standard Series) PDUS35 (S Series)				PDU40 (Standard Series) PDUS40 (S Series)				PDU50 (Standard Series) PDUS50 (S Series)			
	Circular Arc Pitch P		35		Circular Arc Pitch P		40		Circular Arc Pitch P		50	
Specs	Roller Diameter ød		19.05		Roller Diameter ød		22.23		Roller Diameter ød		25.4	
	Overall Width Lw		Standard: 40 S: 34		Overall Width Lw		Standard: 46 S: 44		Overall Width Lw		Standard: 52 S: 46	
	Inside Width W		22		Inside Width W		28		Inside Width W		28	
	Plate Thickness T		Standard: 9 S: 6		Plate Thickness T		Standard: 9 S: 8		Plate Thickness T		Standard: 12 S: 9	
	Mounting Hole ødm		9		Mounting Hole ødm		10.8		Mounting Hole ødm		12.8	
	Mounting Bolt Size		M8		Mounting Bolt Size		M10		Mounting Bolt Size		M12	
	Roller Qty NT	Segment Qty	Pitch Diameter Dpw	Outer Diameter Dow	Inner Diameter Diw	Segment Qty	Pitch Diameter Dpw	Outer Diameter Dow	Inner Diameter Diw	Segment Qty	Pitch Diameter Dpw	Outer Diameter Dow
60	1	668.45	709	628	3	763.94	812	715	3	954.93	1010	899
70	3	779.86	820	739	4	891.27	940	843	4	1114.08	1170	1059
80	4	891.27	932	851	4	1018.59	1067	970	4	1273.24	1329	1218
90	4	1002.68	1043	962	5	1145.92	1194	1097	5	1432.39	1488	1377
100	5	1114.08	1155	1074	5	1273.24	1322	1225	5	1591.55	1647	1536
110	5	1225.49	1266	1185	6	1400.56	1449	1352	6	1750.70	1806	1695
120	6	1336.90	1377	1296	6	1527.89	1576	1479	6	1909.86	1965	1854
130	6	1448.31	1489	1408	7	1655.21	1704	1607	7	2069.01	2125	2014
140	6	1559.72	1600	1519	7	1782.54	1831	1734	7	2228.17	2284	2173
150	7	1671.13	1712	1631	8	1909.86	1958	1861	8	2387.32	2443	2332
160	7	1782.54	1823	1742	8	2037.18	2086	1989	8	2546.48	2602	2491
170	8	1893.94	1934	1853	9	2164.51	2213	2116	9	2705.63	2761	2650
180	8	2005.35	2046	1965	10	2291.83	2340	2243	9	2864.79	2920	2809
190	9	2116.76	2157	2076	10	2419.16	2468	2371	10	3023.94	3079	2968
200	9	2228.17	2269	2188	11	2546.48	2595	2498	11	3183.10	3239	3128
220	10	2450.99	2491	2410	12	2801.13	2850	2753	12	3501.41	3557	3446
240	11	2673.80	2714	2633	13	3055.77	3104	3007	13	3819.72	3875	3764
260	12	2896.62	2937	2856	14	3310.42	3359	3262	14	4138.03	4194	4083
280	13	3119.44	3160	3079	15	3565.07	3614	3517	15	4456.34	4512	4401
300	14	3342.25	3383	3302	16	3819.72	3868	3771	16	4774.65	4830	4719

* We can produce products with roller quantities other than those indicated above.

Pin Wheel Products and Specifications

Frame No.	PDU55 (Standard Series) PDU555 (S Series)				PDU70 (Standard Series) PDU570 (S Series)				PDU80 (Standard Series) PDU580 (S Series)			
Specs	Circular Arc Pitch P	55			Circular Arc Pitch P	70			Circular Arc Pitch P	80		
	Roller Diameter ød	28.58			Roller Diameter ød	35.71			Roller Diameter ød	39.68		
	Overall Width Lw	Standard: 60 S: 54			Overall Width Lw	Standard: 72 S: 60			Overall Width Lw	Standard: 74 S: 66		
	Inside Width W	36			Inside Width W	40			Inside Width W	42		
	Plate Thickness T	Standard: 12 S: 9			Plate Thickness T	Standard: 16 S: 10			Plate Thickness T	Standard: 16 S: 12		
	Mounting Hole ødm	12.8			Mounting Hole ødm	17			Mounting Hole ødm	17		
	Mounting Bolt Size	M12			Mounting Bolt Size	M16			Mounting Bolt Size	M16		
Roller Qty NT	Segment Qty	Pitch Diameter Dpw	Outer Diameter Dow	Inner Diameter Diw	Segment Qty	Pitch Diameter Dpw	Outer Diameter Dow	Inner Diameter Diw	Segment Qty	Pitch Diameter Dpw	Outer Diameter Dow	Inner Diameter Diw
60	3	1050.42	1115	986	4	1336.90	1409	1264	5	1527.89	1608	1447
70	4	1225.49	1290	1161	5	1559.72	1632	1487	6	1782.54	1863	1702
80	5	1400.56	1465	1336	6	1782.54	1855	1710	7	2037.18	2118	1957
90	5	1575.63	1640	1511	7	2005.35	2078	1933	8	2291.83	2372	2211
100	6	1750.70	1815	1686	7	2228.17	2301	2156	9	2546.48	2627	2466
110	6	1925.77	1990	1861	8	2450.99	2523	2378	9	2801.13	2882	2721
120	7	2100.85	2165	2036	9	2673.80	2746	2601	10	3055.77	3136	2975
130	8	2275.92	2340	2211	10	2896.62	2969	2824	11	3310.42	3391	3230
140	8	2450.99	2515	2386	10	3119.44	3192	3047	12	3565.07	3646	3485
150	9	2626.06	2691	2562	11	3342.25	3415	3270	13	3819.72	3900	3739
160	9	2801.13	2866	2737	12	3565.07	3638	3493	13	4074.37	4155	3994
170	10	2976.20	3041	2912	12	3787.89	3860	3715	14	4329.01	4410	4249
180	10	3151.27	3216	3087	13	4010.70	4083	3938	15	4583.66	4664	4503
190	11	3326.34	3391	3262	14	4233.52	4306	4161	16	4838.31	4919	4758
200	12	3501.41	3566	3437	15	4456.34	4529	4384	17	5092.96	5173	5012
220	13	3851.55	3916	3787	16	4901.97	4974	4829	18	5602.25	5683	5522
240	14	4201.69	4266	4137	17	5347.61	5420	5275	20	6111.55	6192	6031
260	15	4551.83	4616	4487	19	5793.24	5866	5721	21	6620.85	6701	6540
280	16	4901.97	4966	4837	20	6238.87	6311	6166	23	7130.14	7211	7050
300	17	5252.11	5317	5188	22	6684.51	6757	6612	25	7639.44	7720	7559

Frame No.	PDU90 (Standard Series) PDU590 (S Series)				PDU120 (Standard Series)			
Specs	Circular Arc Pitch P	90			Circular Arc Pitch P	120		
	Roller Diameter ød	47.63			Roller Diameter ød	63.5		
	Overall Width Lw	Standard: 90 S: 76			Overall Width Lw	Standard: 112		
	Inside Width W	52			Inside Width W	68		
	Plate Thickness T	Standard: 19 S: 12			Plate Thickness T	Standard: 22		
	Mounting Hole ødm	22			Mounting Hole ødm	32		
	Mounting Bolt Size	M20			Mounting Bolt Size	M30		
Roller Qty NT	Segment Qty	Pitch Diameter Dpw	Outer Diameter Dow	Inner Diameter Diw	Segment Qty	Pitch Diameter Dpw	Outer Diameter Dow	Inner Diameter Diw
60	6	1718.87	1815	1622	8	2291.83	2442	2141
70	7	2005.35	2102	1909	9	2673.80	2824	2523
80	8	2291.83	2388	2195	10	3055.77	3206	2905
90	9	2578.31	2675	2482	12	3437.75	3588	3287
100	10	2864.79	2961	2768	13	3819.72	3970	3669
110	11	3151.27	3248	3055	14	4201.69	4352	4051
120	12	3437.75	3534	3341	15	4583.66	4734	4433
130	12	3724.23	3821	3628	16	4965.63	5116	4815
140	13	4010.70	4107	3914	18	5347.61	5498	5197
150	14	4297.18	4394	4201	19	5729.58	5880	5579
160	15	4583.66	4680	4487	20	6111.55	6262	5961
170	16	4870.14	4967	4774	21	6493.52	6644	6343
180	17	5156.62	5253	5060	22	6875.49	7026	6725
190	18	5443.10	5540	5347	24	7257.47	7408	7107
200	19	5729.58	5826	5633	25	7639.44	7790	7489
220	21	6302.54	6399	6206	27	8403.38	8554	8253
240	22	6875.49	6972	6779	30	9167.32	9318	9017
260	24	7448.45	7545	7352	32	9931.27	10082	9781
280	26	8021.41	8118	7925	35	10695.21	10846	10545
300	28	8594.37	8691	8498	37	11459.16	11610	11309

* We can produce products with roller quantities other than those indicated above.

Pin Rack Products and Specifications

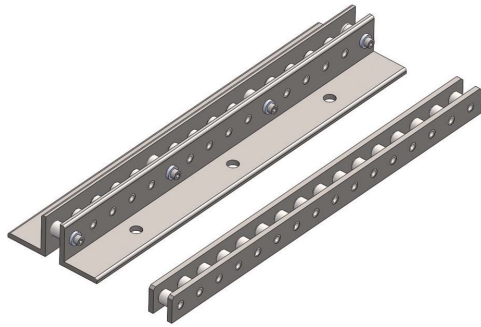

Flat Rack (FR)

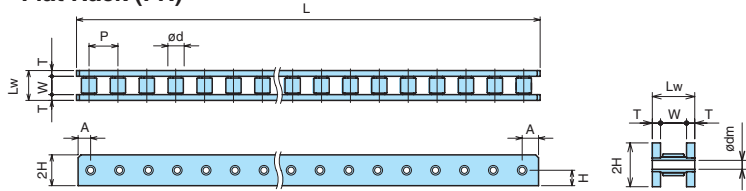

Angle Rack (AR)

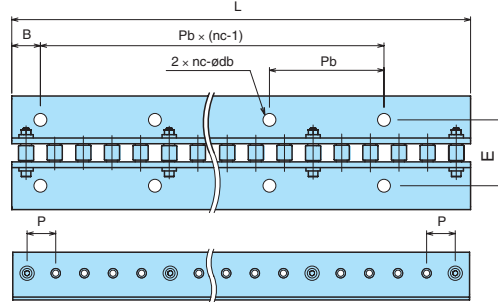

* Hollow pins are secured with nuts and bolts to secure the rack on angle models.

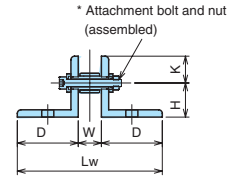

Notes:

1. Long pin rack configurations can be calculated by multiplying the standard length by N pieces or by multiplying the standard length by N pieces and then adding the required number of rollers shorter than standard length.
We can produce products with roller quantities other than those indicated here.
2. See page 8 for installation instructions for flat racks.
3. Mounting bolts are not included.

Flat Rack Specifications Table

Specs	Frame No.	Pitch P	Standard Length		Plate Thickness T	Pin Location A	Inside Width W	Overall Width Lw	Roller Diameter ød	Frame Height 2H	Mounting Hole ødm	Bolt Size	Weight (kg)	Smallest Manufacturable Length	
			Length L	Roller Qty NT										Length L	Roller Qty NT
Standard Series	PDU20	20	800	40	4.5	10	12	21	10.16	22	4.5	M4	1.5	160	8
	PDU22	22	792	36	4.5	11	16	25	11.91	25	4.5	M4	1.8	286	13
	PDU30	30	780	26	6	15	19	31	15.88	32	6.5	M6	3.0	300	10
	PDU35	35	770	22	9	17.5	22	40	19.05	38	9	M8	5.0	280	8
	PDU40	40	800	20	9	20	28	46	22.23	45	10.8	M10	6.4	280	7
	PDU50	50	1000	20	12	25	28	52	25.4	65	12.8	M12	14.0	300	6
	PDU55	55	990	18	12	27.5	36	60	28.58	65	12.8	M12	14.9	495	9
	PDU70	70	980	14	16	35	40	72	35.71	75	17	M16	22.2	420	6
	PDU80	80	960	12	16	40	42	74	39.68	90	17	M16	26.3	560	7
	PDU90	90	990	11	19	45	52	90	47.63	100	22	M20	36.5	540	6
PDU120	120	960	8	22	60	68	112	63.5	150	32	M30	60.7	480	4	
S Series	PDUS20	20	800	40	5	10	12	22	10.16	22	4.5	M4	1.6	160	8
	PDUS22	22	792	36	5	11	16	26	11.91	25	4.5	M4	2.0	286	13
	PDUS30	30	780	26	6	15	19	31	15.88	32	6.5	M6	3.1	300	10
	PDUS35	35	770	22	6	17.5	22	34	19.05	38	9	M8	3.7	280	8
	PDUS40	40	800	20	8	20	28	44	22.23	50	10.8	M10	6.5	280	7
	PDUS50	50	1000	20	9	25	28	46	25.4	65	12.8	M12	11.1	300	6
	PDUS55	55	990	18	9	27.5	36	54	28.58	65	12.8	M12	12.1	495	9
	PDUS70	70	980	14	10	35	40	60	35.71	75	17	M16	15.6	420	6
	PDUS80	80	960	12	12	40	42	66	39.68	90	17	M16	21.3	560	7
	PDUS90	90	990	11	12	45	52	76	47.63	100	22	M20	26.2	540	6

* We can produce products with roller quantities other than those indicated above.

Angle Rack Specifications Table

Specs	Frame No.	Pitch P	Standard Length		Inside Width W	Overall Width Lw	Angle Width D	Center Height		Attachment Hole Location						Bolt Size	Weight (kg)	Smallest Manufacturable Length	
			Length L	Roller Qty NT				H	K	Width E	Edge B	Pitch Pb	Attachment Hole Pitch Pb x (nc-1)	Holes Per Side nc	Hole Diameter ødb			Length L	Roller Qty NT
Standard Series	PDU20	20	800	40	12	72	30	20	10	56	20	120	720	7	9	M8	2.4	160	8
	PDU22	22	792	36	16	96	40	27	13	60	22	88	704	9	11	M10	3.3	132	6
	PDU30	30	780	26	19	119	50	28	22	69	30	120	720	7	13.5	M12	5.9	180	6
	PDU35	35	770	22	22	122	50	30	20	76	35	140	700	6	13.5	M12	7.7	210	6
	PDU40	40	800	20	28	128	50	28	22	88	40	120	720	7	13.5	M12	8.5	320	8
	PDU50	50	1000	20	28	158	65	40	25	104	50	150	900	7	17.5	M16	17.1	250	5
	PDU55	55	990	18	36	166	65	37	28	112	55	165	825	6	17.5	M16	18.0	440	8
	PDU70	70	980	14	Available on inquiry													560	8
	PDU80	80	960	12	Available on inquiry													480	6
	PDU90	90	990	11	Available on inquiry													540	6
S Series	PDU120	120	960	8	Available on inquiry													480	4
	PDUS20	20	800	40	12	72	30	20	10	56	20	120	720	7	9	M8	2.4	160	8
	PDUS22	22	792	36	16	96	40	27	13	60	22	88	704	9	11	M10	3.4	132	6
	PDUS30	30	780	26	19	119	50	28	22	69	30	120	720	7	13.5	M12	6.6	180	6
	PDUS35	35	770	22	22	122	50	30	20	76	35	140	700	6	13.5	M12	6.8	210	6
	PDUS40	40	800	20	28	128	50	28	22	88	40	120	720	7	13.5	M12	7.5	320	8
PDUS50	50	1000	20	28	158	65	40	25	104	50	150	900	7	17.5	M16	13.8	250	5	
PDUS55	55	990	18	36	166	65	37	28	112	55	165	825	6	17.5	M16	14.8	440	8	

*We can produce products with roller quantities other than those indicated above.

Example Model No.

PDU55 - FR - 18P

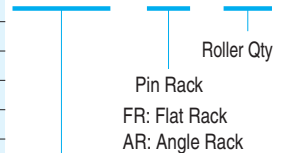

Frame No.
PDU : Standard Series
PDU5 : S Series

Pin Gear Products and Specifications



Example Model No.

PDU90 - S - 1B 24T

Frame No. PDU: Standard Series PDU S: S Series
 Pin Gear G: Outer drive N: Inner drive S: Linear drive
 No. of Teeth Hub Type 1B: B Type 1C: C Type

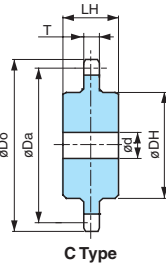
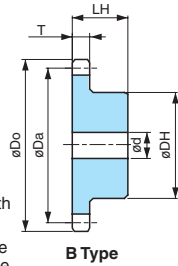

	Standard Series	S Series
Materials	Carbon steel for machine structural use	Stainless steel
Structure	B Type C Type	
Teeth treatment	Induction hardening/tempering	

*Products can also be made from materials other than those indicated above.
 *Shaft hole finishing is also available.
 *Lock type Pin Gear (with friction fastening mechanism) are also available. (See image below.)

Applicable Number of Teeth range for Pin Gear (Standard Series/S Series)

No. of Teeth	Linear Rack	Outer Drive Pin Wheel Roller Qty								Inner Drive Pin Wheel Roller Qty							
		60	70	80	100	150	200	250	300	60	70	80	100	150	200	250	
11	×	×	×	×	×	×	×	×	×	○	○	○	○	×	×	×	
12	△	×	×	×	×	×	×	×	×	○	○	○	○	○	○	○	
13	○	×	×	×	×	×	△	△	△	○	○	○	○	○	○	○	
14	○	×	×	△	△	△	△	△	△	○	○	○	○	○	○	○	
15	○	△	△	△	△	△	△	△	△	○	○	○	○	○	○	○	
16	○	△	△	△	△	△	△	△	△	○	○	○	○	○	○	○	
17	○	△	△	△	△	△	△	△	○	○	○	○	○	○	○	○	
18	○	△	△	△	△	△	△	○	○	○	○	○	○	○	○	○	
19	○	△	△	△	△	○	○	○	○	○	○	○	○	○	○	○	
20	○	△	△	△	○	○	○	○	○	○	○	○	○	○	○	○	
21	○	△	△	○	○	○	○	○	○	○	○	○	○	○	○	○	
22	○	△	○	○	○	○	○	○	○	○	○	○	○	○	○	○	
23	○	△	○	○	○	○	○	○	○	○	○	○	○	○	○	○	
24 and over	○	○	○	○	○	○	○	○	○	○	○	○	○	○	○	○	

○ = Applicable.
 △ = Applicable, but tangential load may be reduced in certain applications. Consult Tsubaki for details.
 × = Not applicable due to insufficient contact ratio.

Pin Gear Specifications Table (Standard Series/S Series)

Frame No.	PDU(S)20					PDU(S)22					PDU(S)30					PDU(S)35				
Type	Pitch P					Pitch P					Pitch P					Pitch P				
	Roller Diameter (Ref.)					Roller Diameter (Ref.)					Roller Diameter (Ref.)					Roller Diameter (Ref.)				
	Tooth Width T					Tooth Width T					Tooth Width T					Tooth Width T				
No. of Teeth	Pitch Diameter Da	Outer Diameter Do	Pilot Bore Diameter d	Hub Diameter DH	Hub Length LH	Pitch Diameter Da	Outer Diameter Do	Pilot Bore Diameter d	Hub Diameter DH	Hub Length LH	Pitch Diameter Da	Outer Diameter Do	Pilot Bore Diameter d	Hub Diameter DH	Hub Length LH	Pitch Diameter Da	Outer Diameter Do	Pilot Bore Diameter d	Hub Diameter DH	Hub Length LH
11	72.43	85	12.7	43	20	80.03	95	12.7	45	30	108.44	129	15.9	65	50	126.55	151	23	75	80
12	78.59	91	12.7	49	20	86.83	102	12.7	50	40	117.79	138	19.0	75	50	137.49	162	23	85	80
14	91.13	105	12.7	50	30	100.44	115	15.9	60	40	136.49	157	19.0	80	50	159.57	184	23	110	90
16	103.66	116	12.7	50	30	114.05	129	15.9	70	40	155.39	176	19.0	80	60	181.65	206	28	120	100
18	116.19	129	12.7	60	30	127.85	143	15.9	70	50	174.29	194	19.0	90	60	203.74	228	28	120	100
20	128.72	141	12.7	60	30	141.66	157	15.9	70	50	192.99	213	23.0	90	70	225.82	250	28	130	100
22	141.46	154	15.9	60	40	155.66	171	15.9	70	50	212.08	232	23.0	90	70	247.90	272	33	130	110
24	153.99	167	15.9	60	40	169.47	184	18.0	70	50	230.98	251	23.0	100	70	269.58	294	33	130	110

Frame No.	PDU(S)40					PDU(S)50					PDU(S)55					PDU(S)70				
Type	Pitch P					Pitch P					Pitch P					Pitch P				
	Roller Diameter (Ref.)					Roller Diameter (Ref.)					Roller Diameter (Ref.)					Roller Diameter (Ref.)				
	Tooth Width T					Tooth Width T					Tooth Width T					Tooth Width T				
No. of Teeth	Pitch Diameter Da	Outer Diameter Do	Pilot Bore Diameter d	Hub Diameter DH	Hub Length LH	Pitch Diameter Da	Outer Diameter Do	Pilot Bore Diameter d	Hub Diameter DH	Hub Length LH	Pitch Diameter Da	Outer Diameter Do	Pilot Bore Diameter d	Hub Diameter DH	Hub Length LH	Pitch Diameter Da	Outer Diameter Do	Pilot Bore Diameter d	Hub Diameter DH	Hub Length LH
11	145.66	174	28	90	80	181.47	214	33	100	90	200.18	237	33	120	140	252.30	298	43	157	150
12	157.79	186	28	100	90	196.59	229	33	110	100	216.08	253	33	135	140	273.98	320	43	170	160
14	182.65	211	28	120	100	227.62	260	33	130	110	250.30	287	33	160	140	317.94	364	43	180	160
16	207.72	236	33	120	100	259.05	292	33	140	120	284.91	322	33	170	150	362.11	408	43	190	160
18	232.58	261	33	130	100	290.48	323	33	140	130	319.53	356	33	170	160	406.07	452	43	190	170
20	257.85	286	33	130	110	321.91	354	33	150	140	354.14	391	33	180	160	450.43	496	43	200	190
22	283.31	312	33	140	120	353.74	386	33	150	140	389.15	426	38	180	160	495.00	541	63	210	190
24	308.18	337	33	140	120	384.97	417	33	160	140	423.57	460	38	190	170	538.76	585	63	210	190

Frame No.	PDU(S)80					PDU(S)90					PDU120				
Type	Pitch P					Pitch P					Pitch P				
	Roller Diameter (Ref.)					Roller Diameter (Ref.)					Roller Diameter (Ref.)				
	Tooth Width T					Tooth Width T					Tooth Width T				
No. of Teeth	Pitch Diameter Da	Outer Diameter Do	Pilot Bore Diameter d	Hub Diameter DH	Hub Length LH	Pitch Diameter Da	Outer Diameter Do	Pilot Bore Diameter d	Hub Diameter DH	Hub Length LH	Pitch Diameter Da	Outer Diameter Do	Pilot Bore Diameter d	Hub Diameter DH	Hub Length LH
11	288.11	339	43	180	150	325.13	387	43	210	180	435.17	517	63	250	240
12	312.78	364	43	190	160	352.77	414	43	220	190	472.37	554	63	260	240
14	363.11	414	43	200	180	409.07	470	43	230	210	546.76	629	63	270	250
16	413.64	465	43	210	200	465.97	527	63	240	230	621.15	703	63	280	260
18	463.97	515	43	220	200	522.66	584	63	250	250	696.95	779	63	290	280
20	514.50	566	63	230	200	579.56	641	63	260	250	772.54	855	68	300	300
22	565.43	617	63	230	210	636.85	698	63	270	260	848.94	931	68	310	320
24	615.55	667	63	240	230	692.95	754	63	270	260	923.73	1006	68	320	320

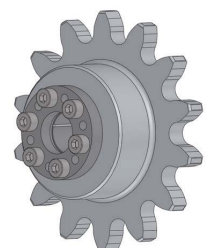

Lock type Pin Gear

*Pin gear tooth profile differs according to application (outer/inner/linear drive).

■ Installation

Inner drive Pin Wheel

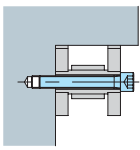

Flat Racks

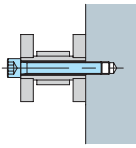

The side of the rack/wheel can be attached to the device with a bolt using the hole in the hollow pin.
When installing, a stopper or guide can be fixed to the projected surface to position the wheel.

Angle Racks

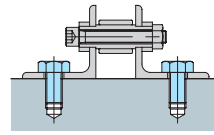

Angle racks can be attached to the device using the mounting bolt holes on the feet of the rack.

■ Mounting Bolt Position

At least the minimum number of bolts (see table below) must be used at both end of each segment and at regularly spaced intervals in between.

■ Minimum Mounting Bolt Quantity per Segment for Pin Wheels & Flat Racks

Type	Frame No.	Mounting Bolt Size	Minimum Qty
Standard Series	PDU20	M4	8
	PDU22	M4	13
	PDU30	M6	10
	PDU35	M8	8
	PDU40	M10	7
	PDU50	M12	6
	PDU55	M12	9
	PDU70	M16	6
	PDU80	M16	7
	PDU90	M20	6
PDU120	M30	4	
S Series	PDUS20	M4	8
	PDUS22	M4	13
	PDUS30	M6	10
	PDUS35	M8	8
	PDUS40	M10	7
	PDUS50	M12	6
	PDUS55	M12	9
	PDUS70	M16	6
	PDUS80	M16	7
	PDUS90	M20	6

Example: Bolt mounting : PDU55-GW-64P 4-segment model
Mounting position : See figure below.
(Mounting bolt positions indicated by black dots.)

PDU55 requires a minimum of 9, M12 mounting bolts.
Install at least 9 bolts per segment as evenly as possible.
* Contact Tsubaki if you are unsure about installation.

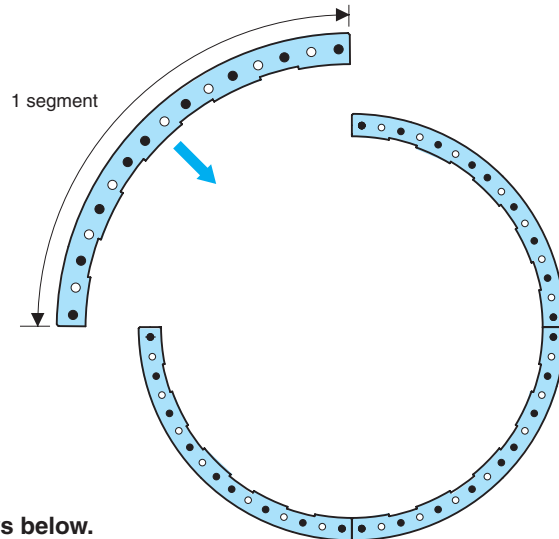

■ Mounting bolts: Use the hexagon socket cap screws below.

Standard series: JIS strength 12.9

S series: JIS strength 50

■ Pin Wheel/Pin Rack Segments

See below for example pin wheel/pin rack segment configurations. Always check production drawings, etc., when ordering.

Example 1: Pin wheel

Model No. PDU30-GW-190P

8 segments (See Specifications Table on page 4.)

Configuration is: { 23/190P x 2 segments
and
24/190P x 6 segments

Example 2: Pin rack

Model No. PDU30-FR-200P

Number of standard length rollers: 26 Minimum roller quantity: 10 (See Specifications Table on page 6.)

Configuration is: { 26P x 7 pieces
and
18P x 1 piece

Pin Gear Drive Selection Procedure

■ Selection Procedure

1. Pre-select the pitch circle diameter of the pin gear drive unit

- For rotational operation: Pre-select the pitch circle diameter of the pin wheel to suit the size of the equipment. Find out the reduction gear ratio required, then pre-select the pitch circle diameter of the pin gear.
- For linear operation: Pre-select the pitch circle diameter of the pin gear based on the equipment layout.

2. Calculate the applied tangential load (Fw)

Calculate the applied tangential load (Fw) that will act on the pin wheel or pin rack based on load conditions.

3. Calculate the corrected tangential load (Ft)

To calculate the corrected tangential load (Ft), obtain the service factor (Ks, Table 1) based on operating conditions, obtain the speed factor (Kv, Table 2) based on the tangential speed, and then multiply the product thereof by the applied tangential load (Fw).

$$F_t = K_s \times K_v \times F_w$$

4. Select the frame number of the pin gear drive unit.

Using the allowable tangential load (Fp) of each pin wheel/pin rack frame number and the corrected tangential load (Ft), select the appropriate pin gear drive unit that satisfies the following condition:

$$\text{Allowable tangential load (Fp)} > \text{Corrected tangential load (Ft)}$$

5. Select the model number

- Pin wheels: From the selected frame number and the pre-selected pin wheel pitch circle diameter, choose the quantity of rollers of the pin wheel closest to the pitch circle diameter.
- Pin racks: From the selected frame number and the total running distance (or total movement distance), calculate the quantity of rack rollers.
- Pin gears: From the selected frame number and the pre-selected pin gear pitch circle diameter, choose the model number of the pin gear with the number of teeth closest to the pitch circle diameter.

Note: There are limits to the extent to which numbers of gear teeth can be used. (See table on page 7.)
If a gear does not have enough teeth, select a gear with a larger number of teeth.

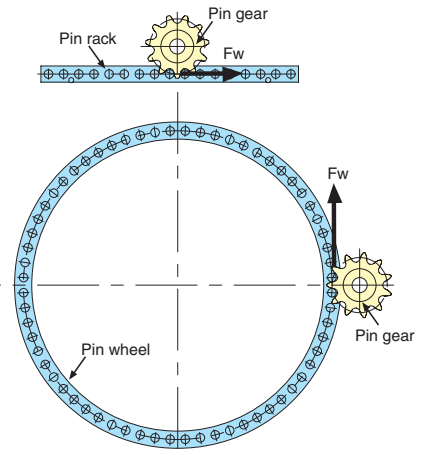

Table 1: Service Factor (Ks)

Operation Status	Operating Hours/Day		
	Up to 3 hrs	Up to 12 hrs	Up to 24 hrs
Even load	1.00 (1.25)	1.15 (1.40)	1.25 (1.50)
Load with small impacts	1.25 (1.50)	1.40 (1.70)	1.60 (2.00)
Load with large impacts	1.50 (1.80)	1.75 (2.15)	2.00 (2.50)

Use values in parentheses if operation stops 10 or more times an hour.

Table 2: Speed Factor (Kv)

Tangential speed: 50m/min.								
0	10	15	20	25	30	35	40	50
1.02	1.04	1.05	1.06	1.06	1.07	1.08	1.1	1.2

Note: Allowable tangential speed is 50 m/min. for all frame numbers.

Lubrication

Before operation, coat all peripheral roller surfaces with extreme pressure grease. The interior of pin wheel and pin rack rollers are pre-coated with lubricating grease. Contact Tsubaki if using in environments where lubricating grease cannot be used, such as under water, or if using at temperatures of 130°C or higher.

Special Specifications

We can produce models with the specifications indicated below. Contact Tsubaki for more information.

Surface treatments	<ul style="list-style-type: none"> ● Blackening Good appearance and effective against rust. ● Electroless nickel plating Corrosion- and wear-resistant characteristics. ● NEP treatment (proprietary Tsubaki surface treatment) NEP treatment with excellent corrosion- and weather-resistant characteristics.
Lock type pin gears	<ul style="list-style-type: none"> ● Pin gear with friction fastening mechanism (Easy phase adjustment. See page 7 for details.) (Not available in S series.)
Low backlash	We can make products with only two-thirds or half the standard amount of backlash.

Installation Precision

· Pin wheels: Projections on the pin wheel frame share the same centers as the roller mounting holes, so projections can be used as a reference surface for centering when fitting the pin wheel into the pilot section on the equipment. The precision of equipment pilot section must be finished within the precision of pilot section runout indicated in the table below.

· Pin racks: Ensure that the parallelism of the equipment-side mounting reference surface of the pin rack and the pin gear center is equal to or less than the indicated value of gear center parallelism in the table below by ensuring that the machine is correctly aligned in advance.

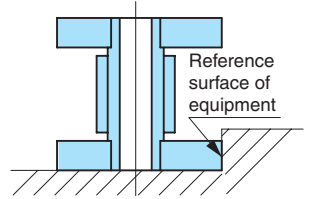

Ensure that the alignment along the A and B axes of adjoining pin racks is within the tolerance indicated in the table below.

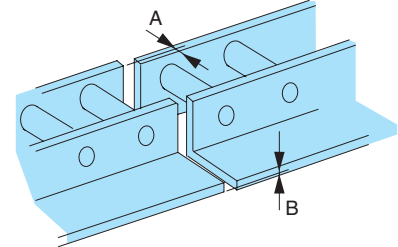
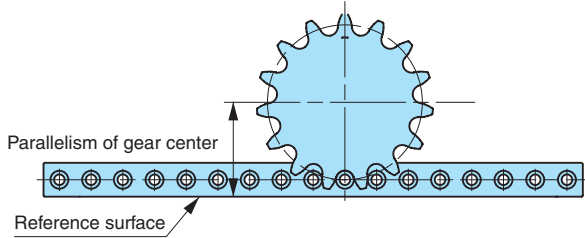

*Always read the instruction manual before installing.

Frame No.		PDU20 PDUS20	PDU22 PDUS22	PDU30 PDUS30	PDU35 PDUS35	PDU40 PDUS40	PDU50 PDUS50	PDU55 PDUS55	PDU70 PDUS70	PDU80 PDUS80	PDU90 PDUS90	PDU120
Rotational drive	Precision of pilot section runout (mm)	0.3	0.3	0.4	0.5	0.6	0.7	0.8	0.9	1.0	1.2	1.6
Linear drive	Parallelism of gear center (mm)	0.3	0.3	0.4	0.5	0.6	0.7	0.8	0.9	1.0	1.2	1.6
	Misalignment tolerance of A and B axes (mm)	0.1	0.2	0.2	0.3	0.3	0.4	0.4	0.5	0.5	0.6	0.8

Reference Material concerning Corrosion Resistance in the S Series

Corrosion resistance may be altered significantly depending on conditions of usage and the table below does not indicate any level of assurance. Refer to the table below and use a test sample under actual conditions of usage to confirm corrosion resistance before use.

○: Sufficient corrosion resistance △: Corrosion resistance depending on operating conditions ×: No corrosion resistance —: Uncertain

Name of Chemical/Foodstuff	Rating	Name of Chemical/Foodstuff	Rating	Name of Chemical/Foodstuff	Rating
Acetone	20°C ○	Developer (photographic)	20°C △	Kerosene	20°C ○
Oil (vegetable/mineral)	20°C ○	Synthetic detergents	○	Varnish	○
Linseed oil	100% 20°C △	Coffee	Boiling ○	Concentrated nitric acid	65% 20°C ×
Sulfur dioxide gas (damp)	20°C ×	Cola syrup	○	Concentrated nitric acid	65% Boiling ×
Alcohol (methyl/ethyl/propyl/butyl)	○	Acetic acid	10% 20°C ○	Lactic Acid	10% 20°C △
Aqueous ammonia	20°C ○	Sugar solution	20°C ○	Honey, Molasses	○
Whiskey	20°C ○	Calcium hypochlorite (bleaching powder) effective chlorine	1%~14% 20°C ×	Paraffin	20°C ○
Ethers (Ethyl ethers)	20°C ○	Sodium hypochlorite	10% 20°C ×	Beer	20°C ○
Zinc chloride	50% 20°C ×	Sodium cyanide	20°C —	Picric acid	Saturated 20°C ○
Ammonium chloride	50% 20°C ×	Carbon tetrachloride (dry)	20°C ○	Fruit juice	20°C △
Potassium chloride	Saturated 20°C △	Potassium dichromate	10% 20°C ○	Benzene	20°C ○
Calcium chloride	Saturated 20°C ×	Oxalic acid	10% 20°C △	Boric acid	50% 100°C ○
Ferric chloride	5% 20°C ×	Tartaric acid	10% 20°C ○	Formalin (formaldehyde)	40% 20°C ○
Sodium chloride	5% 20°C △	Nitric acid	5% 20°C △	Mayonnaise	20°C △
Hydrochloric acid	2% 20°C ×	Ammonium nitrate	Saturated Boiling ○	Water	○
Chlorine gas (dry)	20°C ×	Potassium nitrate	25% 20°C ○	Vegetable Juice	20°C ○
Chlorine gas (damp)	20°C ×	Potassium nitrate	25% Boiling point ×	Lard	○
Chlorine water	×	Vinegar	20°C ×	Butyric acid	20°C ○
Oleic acid	20°C ○	Potassium hydroxide (caustic potash)	20% 20°C ○	Hydrogen sulfide (dry)	○
Seawater	20°C ×	Calcium hydroxide (slaked lime)	Boiling ○	Hydrogen sulfide (damp)	×
Sodium perchlorate	10% Boiling point ×	Sodium hydroxide (caustic soda)	25% 20°C ○	Sulfuric acid	5% 20°C ×
Hydrogen peroxide	30% 20°C △	Stearic acid	100% Boiling point ×	Zinc sulfate	25% Saturated 20°C ○
Gasoline	20°C ○	Soft drink	20°C ○	Aluminum sulfate	Saturated 20°C ×
Permanganate	Saturated 20°C ○	Phenol	20°C ○	Ammonium sulfate	Saturated 20°C △
Formic acid	50% 20°C ○	Petroleum	20°C ○	Sodium sulfate	Saturated 20°C ○
Milk	20°C ○	Soapsuds	20°C ○	Malic acid	50% 20°C ○
Citric acid	50% 20°C ○	Carbonated water	20°C ○	Phosphoric acid	5% 20°C △
Glycerin	20°C ○	Sodium bicarbonate	20°C ○	Phosphoric acid	10% 20°C △
Creosote	20°C ○	Sodium carbonate	Saturated Boiling point ○	Wine	20°C ○
Chromic acid	5% 20°C △	Sodium thiosulfate	25% Boiling point ○		
Ketchup	20°C ○	Turpentine	35°C ○		

Example Uses 1

■ Environmental sanitation equipment

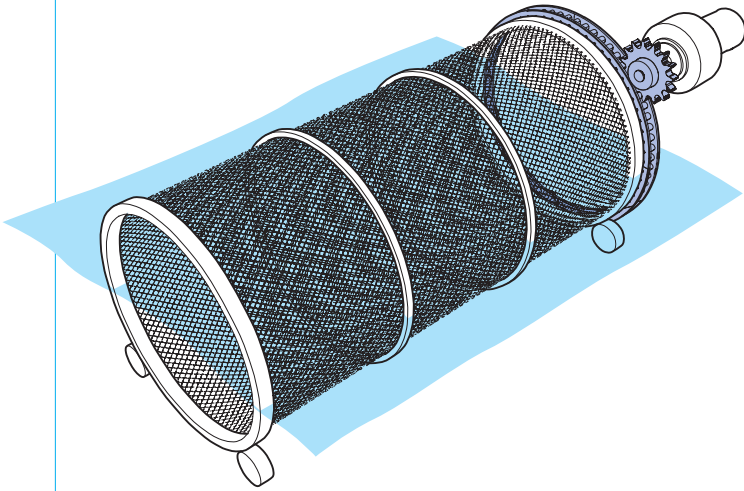

■ Welding roll over

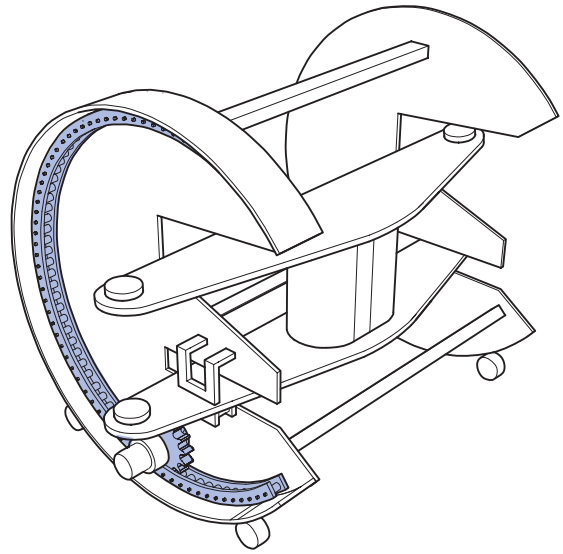

■ Railroad turntable

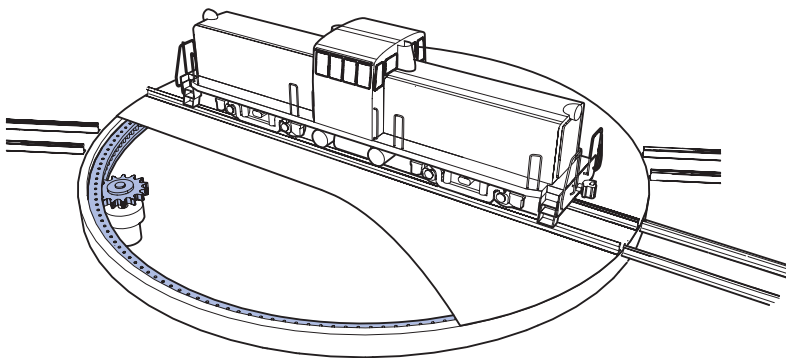

■ Revolving door mechanism

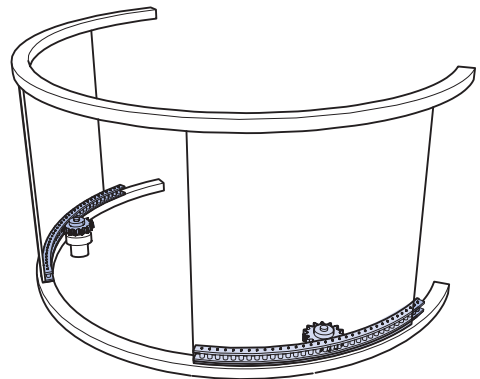

■ Casting line

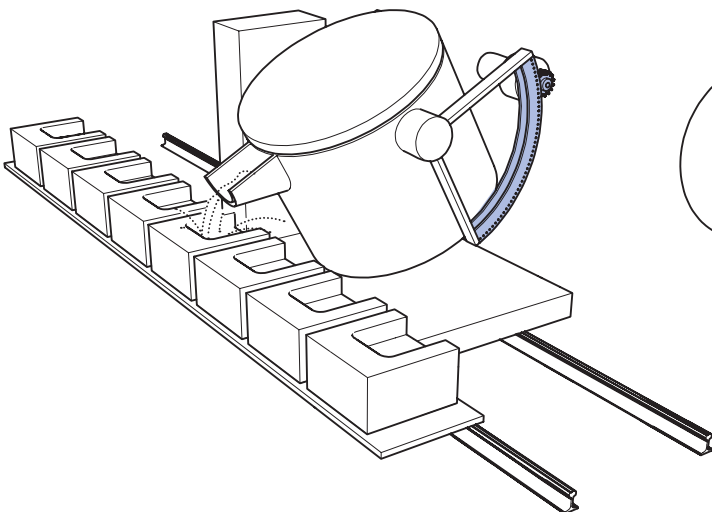

■ Rotary kiln

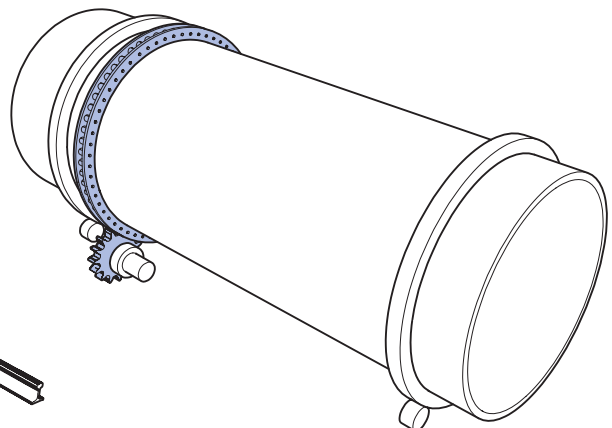

Example Uses 2

■ Drive for large transporter

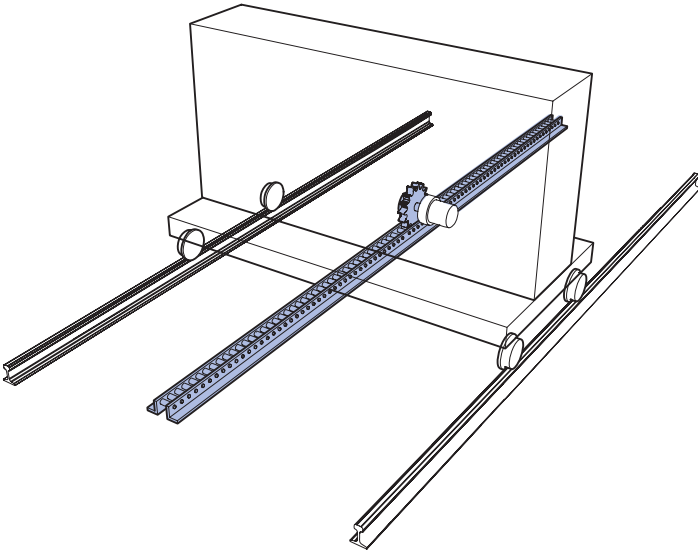

■ Solar tracking system

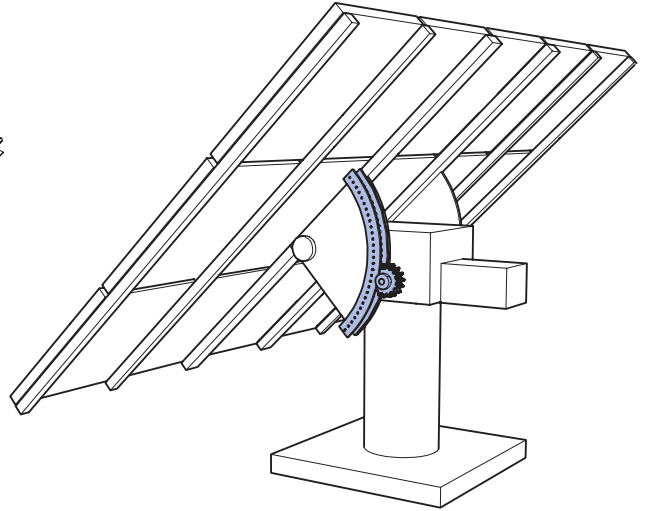

■ Pallet changer for machine tool

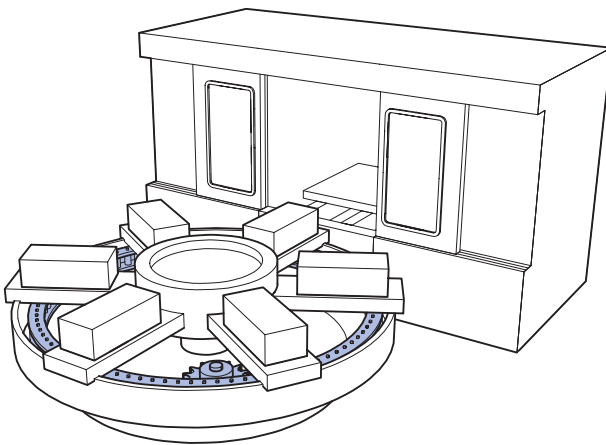

■ Handling robot

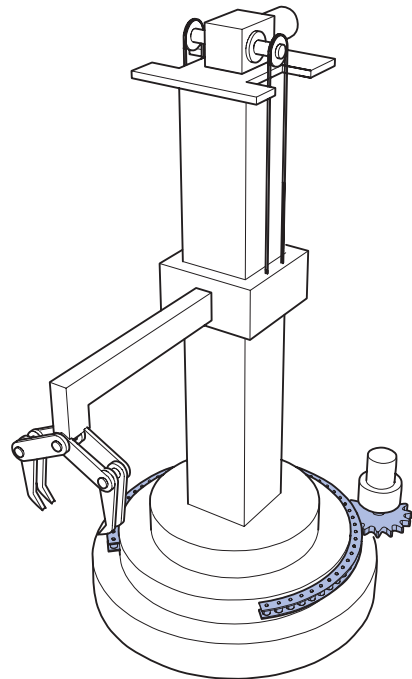

■ Pallet pool for machine tool

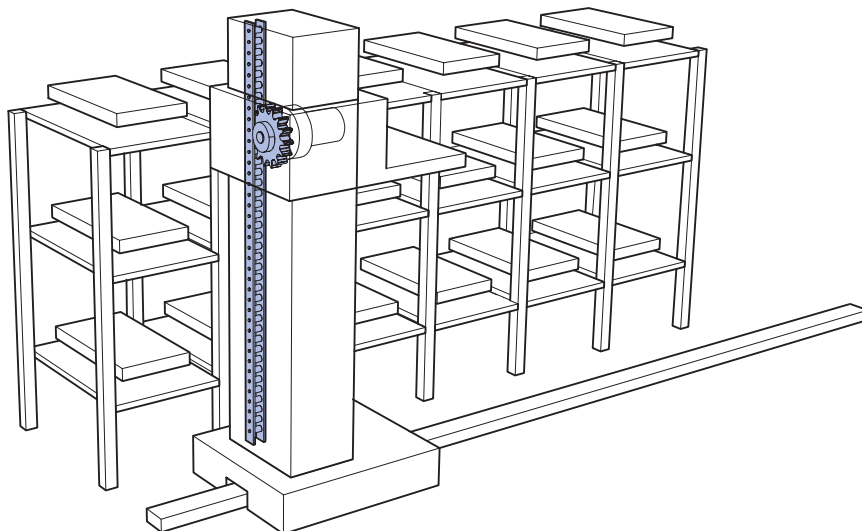

Safety Precautions



WARNING Observe the items below to prevent danger.

- Check that no torque is acting on the rotating shaft of the product or the equipment before installation and before performing maintenance and inspection work.
- Product function or performance may be adversely affected by mounting accuracy and load conditions or the wear and life of parts used. Implement safety measures for the equipment in advance and regularly perform maintenance and inspections.
- Follow all applicable local safety regulations as required.
- Observe the following when installing, removing, maintaining, or inspecting the product:
 - Wear suitable clothes and protective gear (e.g., safety glasses, gloves, and shoes) when working.
 - Turn off the main power switch of the equipment before conducting the work and take preventive measures so that the switch will not be turned on unexpectedly. Take the same precautions during a power failure.
 - Read and follow the instructions in the operation manuals and catalogs before conducting the work.
- If a load is always imposed on the equipment (e.g., hoisting equipment), eliminate the load or take appropriate measures to prevent the load from falling before performing maintenance and inspection work.



CAUTION Observe the items below to prevent accidents.

- Great force will act on the mount if the product is used for applications where the product is started and stopped frequently. Make sure that the mount is sturdy enough.
- The product is provided with an operation manual. Be sure to read the operation manual before using the product and always use the product correctly. Request an operation manual from your dealer or Tsubaki dealer if the operation manual is not on hand.
- Always make sure that the operation manual is delivered to the end user.

Warranty

1. Warranty period without charge

Tsubakimoto Sprocket Co. (hereinafter referred to as "Company") provides a warranty without charge valid for either 18 months after the shipment of the purchased product (hereinafter referred to as "Goods") from the factory, or 12 months after the first use of Goods, whichever comes first. First use of Goods is considered to be the complete incorporation of Goods into the equipment of the purchasing party (hereinafter referred to as "Customer"). This warranty may be provided with charge in certain circumstances.

2. Warranty coverage

Should any malfunction in Goods arise during the warranty period, given that Goods were properly installed, operated, and maintained as instructed in the catalog, instruction manual, or similar, Company shall promptly deliver or repair Goods or the failed part at no charge once Company has confirmed such failure. This warranty only covers delivered Goods and therefore does not include the following: ("Instruction manual or similar" includes documentation specially provided to Customer.)

- (1) Any costs required for the removal or mounting of Goods from or into Customer's equipment for repair or replacement.
- (2) Costs required for transporting Customer's equipment to repair shop, etc.
- (3) Profits lost due to a malfunction or repair, or any other consequential loss.

3. Warranty with charge

Company will charge for any investigation and repair of a malfunction in Goods (even during the warranty period) if caused by:

- (1) Improper location, installation, lubrication, or maintenance by Customer's failing to follow the catalog, instruction manual, or similar. ("Instruction manual or similar" includes documentation specially provided to Customer.)
- (2) Operation methods (including usage conditions, usage environment, and allowable values) resulting from Customer's failure to follow operation described in the catalog, instruction manual, or similar. ("Instruction manual or similar" includes documentation specially provided to Customer.)
- (3) Inappropriate disassembly, modification, alteration, or processing by Customer.
- (4) Use of Goods by Customer in conjunction with damaged or worn parts not made by Company.
- (5) Failure of operational life under conditions of use as determined by Company to satisfy operational life covered by Warranty.
- (6) Use by Customer under conditions other than those discussed.
- (7) Consumption, wear, or deterioration of bearings, oil seals, oil, and other consumable parts incorporated into Goods.
- (8) Secondary failure or malfunction resulting from malfunctioning of Customer's equipment.
- (9) Malfunction of Goods resulting from a Force Majeure such as an act of God.
- (10) Malfunction of Goods resulting from a wrongful act committed by a third party.
- (11) Any other reason that is not attributable to Company.



CAUTION

Product details described in this catalog are primarily intended to aid product selection. Always read the instruction manual before using any product to ensure correct use.

TSUBAKIMOTO CHAIN CO.

Headquarters

Nakanoshima Mitsui Building
3-3-3 Nakanoshima, Kita-ku
Osaka 530-0005, Japan
Phone : +81-6-6441-0011
Facsimile : +81-6-6441-0489
Internet:
<http://tsubakimoto.com/>

Chain & Power Transmission Operations

Chain Products Department

1-3 Kannabidai 1-chome
Kyotanabe, Kyoto 610-0380, Japan
Phone : +81-774-64-5100
Facsimile : +81-774-64-5212



Kyotanabe Plant

Global Associated Partners:

NORTH and SOUTH AMERICA

U.S. TSUBAKI

POWER TRANSMISSION, LLC

301 E. Marquardt Drive
Wheeling, IL 60090-6497
U.S.A.
Phone : +1-847-459-9500
Facsimile : +1-847-459-9515

TSUBAKI of CANADA LIMITED

1630 Drew Road
Mississauga, Ontario, L5S 1J6
Canada
Phone : +1-905-676-0400
Facsimile : +1-905-676-0904

TSUBAKI BRASIL

EQUIPAMENTOS INDUSTRIAIS LTDA.

Rua Pamplona, 1018 - CJ. 73/74
Jardim Paulista, CEP 01405-001
São Paulo - S.P. Brazil
Phone : +55-11-3253-5656
Facsimile : +55-11-3253-3384

EUROPE

TSUBAKIMOTO EUROPE B.V.

Aventurijn 1200, 3316 LB Dordrecht
The Netherlands
Phone : +31-78-6204000
Facsimile : +31-78-6204001

TSUBAKIMOTO U.K. LTD.

Osier Drive, Sherwood Park
Annesley, Nottingham
NG15 0DX U.K.
Phone : +44-1623-688-700
Facsimile : +44-1623-688-789

TSUBAKI DEUTSCHLAND GmbH

ASTO Park Oberpfaffenhofen
Friedrichshafener Straße 1
D-82205 Gilching, Germany
Phone : +49-8105-7307100
Facsimile : +49-8105-7307101

ASIA and OCEANIA

TSUBAKIMOTO SINGAPORE PTE. LTD.

25 Gul Lane
Jurong
Singapore 629419
Phone : +65-6861-0422/3/4
Facsimile : +65-6861-7035

TSUBAKIMOTO SINGAPORE PTE. LTD.

VIETNAM REPRESENTATIVE OFFICE

8F H&H Building, 209 Hoang Van Thu
Phu Nhuan District, Ho Chi Minh City
Vietnam
Phone : +84-8-3999-0131 or 0132
Facsimile : +84-8-3999-0130

TSUBAKIMOTO SINGAPORE PTE. LTD.

INDONESIA REPRESENTATIVE OFFICE

Wisma Kyoei Prince, 11th Floor, Suite 1106
Jl. Jend. Sudirman, Kav. 3, Jakarta 10220
Indonesia
Phone : +62-21-5724-275
Facsimile : +62-21-5724-275

TSUBAKIMOTO CHAIN TRADING (SHANGHAI) CO., LTD.

Room 601, Urban City Centre
45 Nanchang Rd., Huangpu District
Shanghai 200020, China
Phone : +86-21-5396-6651/6652
Facsimile : +86-21-5396-6628

KOREA CONVEYOR IND. CO., LTD.

68B-7L, NamDong GongDan,
627-4, Gojan Dong, NamDong Gu,
Incheon city, Korea
Phone : +82-32-817-0160
Facsimile : +82-32-819-9168

TAIWAN TSUBAKIMOTO CO.

No. 33, Lane 17, Zihciang North Road
Gueishan Township, Taoyuan County
Taiwan
Phone : +886-33-293827/8/9
Facsimile : +886-33-293065

TSUBAKIMOTO (THAILAND) CO., LTD.

388 Exchange Tower, 19th Floor Unit
1902, Sukhumvit Road, Klongtoey
Bangkok 10110 Thailand
Phone : +66-2-262-0667/8/9 (3 lines)
Facsimile : +66-2-262-0670

TSUBAKI INDIA

POWER TRANSMISSION PTE. LTD.

Chandrika Chambers No.4, 3rd Floor
Anthony Street, Royapettah
Chennai-600014, Tamil Nadu, India
Phone : +91-44-4231-5251
Facsimile : +91-44-4231-5253

TSUBAKI AUSTRALIA PTY. LTD.

Unit E, 95-101 Silverwater Road
Silverwater, N.S.W. 2128
Australia
Phone : +61-2-9704-2500
Facsimile : +61-2-9704-2550

Distributed by: